

# EG1226 (12 V 26AH) Deep Cycle



## Specification

Nominal Voltage	12V	
Nominal Capacity(20HR)	26.0AH	
Dimension	Length	166±2mm (6.54 inches)
	Width	175±2mm (6.89 inches)
	Container Height	125±2mm (4.92 inches)
	Total Height (with Terminal)	125±2mm (4.92 inches)
Approx Weight	Approx 7.7 kg ( ±%3 )	
Design Life	10 year for standby use	
Container Material	ABS	
Rated Capacity	26.0 AH/1.30A	(20hr, 1.80V/cell, 25°C/77°F)
	24.2 AH/2.42A	(10hr, 1.75V/cell, 25°C/77°F)
	20.8 AH/4.16A	(5hr, 1.75V/cell, 25°C/77°F)
	18.1 AH/6.03A	(3hr, 1.75V/cell, 25°C/77°F)
	14.3 AH/14.3A	(1hr, 1.67V/cell, 25°C/77°F)
Max. Discharge Current	312A (5s)	
Internal Resistance	Approx 13.5mΩ	
Operating Temp. Range	Discharge : -20~55°C (-4~131°F)	
	Charge : 0~40°C (32~104°F)	
	Storage : -20~50°C (-4~122°F)	
Nominal Operating Temp. Range	25±3°C (77±5°F)	
Cycle Use	Initial Charging Current less than 6.5A. Voltage	
	14.4V~15.0V at 25°C(77°F)Temp. Coefficient -30mV/°C	
Standby Use	No limit on Initial Charging Current Voltage	
	13.5V~13.8V at 25°C(77°F)Temp. Coefficient -20mV/°C	
Capacity affected by Temperature	40°C (104°F)	103%
	25°C (77°F)	100%
	0°C (32°F)	86%
Self Discharge	EG series batteries may be stored for up to 9 months at 25°C(77°F) and then a freshening charge is required.	
	For higher temperatures the time interval will be shorter.	

## Applications

- ◆ Telecommunications
- ◆ Solar system
- ◆ Wind power system
- ◆ Engine starting
- ◆ Wheelchair
- ◆ Floor cleaning machines
- ◆ Golf trolley
- ◆ Boats



## Constant Current Discharge (Amperes) at 25 °C (77°F)

F.V/Time	20min	30min	45min	1h	2h	3h	4h	5h	6h	7h	8h	9h	10h	20h
1.85V/cell	22.0	17.3	13.2	11.0	6.99	5.33	4.41	3.81	3.29	2.91	2.63	2.40	2.27	1.25
1.80V/cell	25.2	19.3	14.5	12.2	7.57	5.71	4.68	4.00	3.45	3.05	2.75	2.52	2.37	1.30
1.75V/cell	28.3	21.2	15.7	13.0	8.02	6.03	4.90	4.16	3.58	3.16	2.84	2.60	2.42	1.33
1.70V/cell	30.5	22.7	16.7	13.8	8.50	6.28	5.06	4.29	3.70	3.26	2.93	2.67	2.48	1.34
1.67V/cell	31.7	23.6	17.3	14.3	8.72	6.48	5.19	4.38	3.76	3.31	2.97	2.70	2.50	1.36
1.60V/cell	34.4	25.3	18.5	15.2	9.07	6.74	5.38	4.51	3.85	3.38	3.02	2.76	2.55	1.38

## Constant Power Discharge (Watts/cell) at 25 °C (77°F)

F.V/Time	20min	30min	45min	1h	2h	3h	4h	5h	6h	7h	8h	9h	10h	20h
1.85V/cell	42.1	33.3	25.5	21.5	13.7	10.4	8.68	7.52	6.52	5.78	5.23	4.78	4.53	2.49
1.80V/cell	47.6	36.8	28.0	23.6	14.7	11.1	9.17	7.88	6.82	6.03	5.46	5.02	4.72	2.59
1.75V/cell	52.9	40.1	30.0	25.1	15.6	11.8	9.57	8.16	7.04	6.23	5.62	5.16	4.81	2.64
1.70V/cell	56.4	42.6	31.6	26.4	16.4	12.2	9.86	8.39	7.27	6.43	5.78	5.29	4.92	2.67
1.67V/cell	58.0	43.8	32.5	27.2	16.7	12.5	10.1	8.54	7.36	6.50	5.86	5.35	4.97	2.69
1.60V/cell	62.2	46.4	34.7	28.8	17.3	13.0	10.4	8.78	7.52	6.62	5.95	5.45	5.06	2.73

## T12 Terminal

Unit: mm [inches]

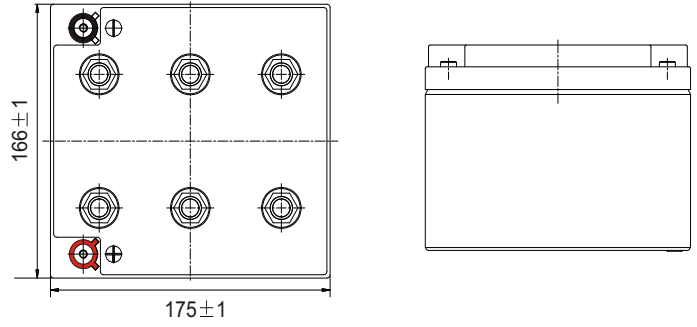
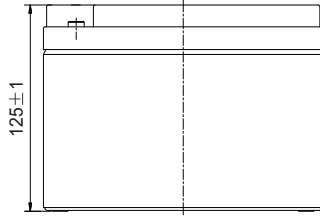
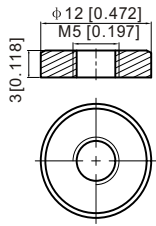

## Discharge Characteristics

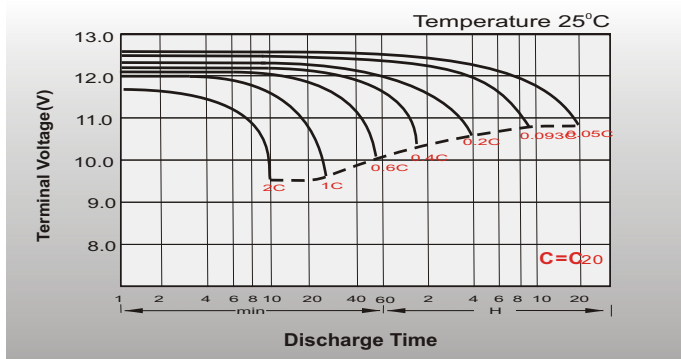

## Float Charging Characteristics

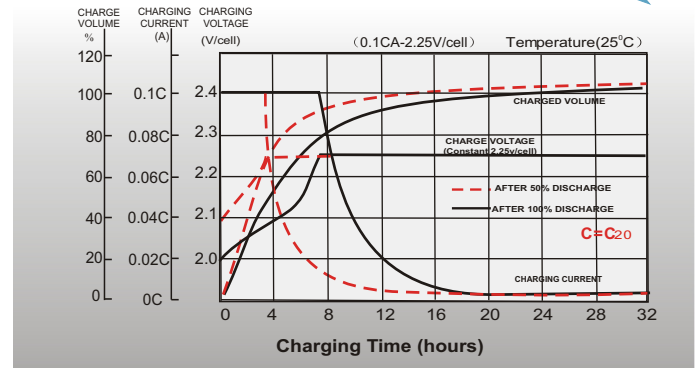

## Temperature Effects in Relation to Battery Capacity

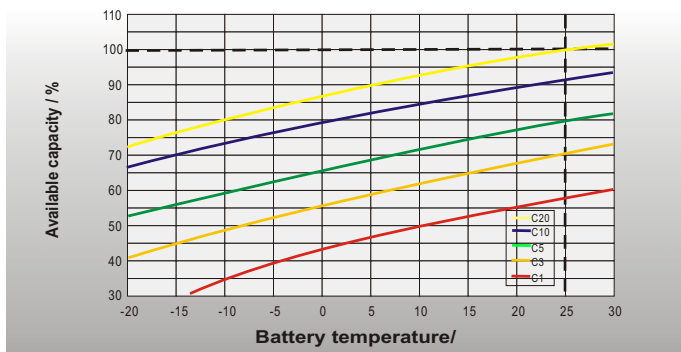

## Effect of Temperature on Long Term Float Life

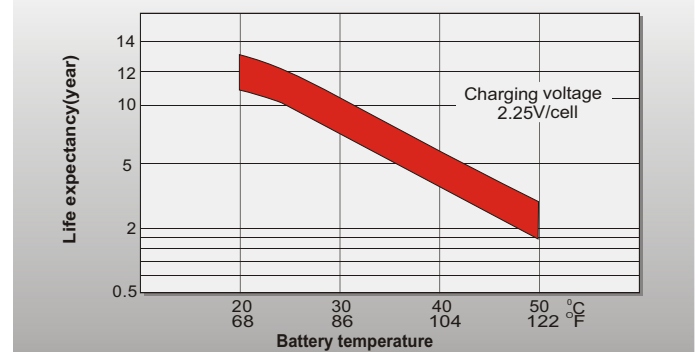

## Cycle Life in Relation to Depth of Discharge

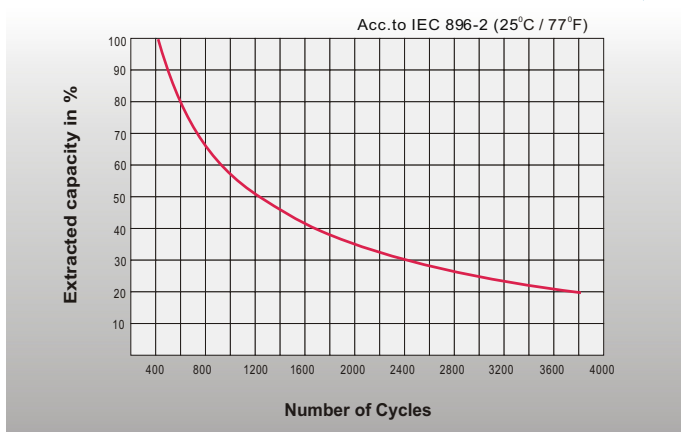

## General Relation of Capacity VS. Storage Time

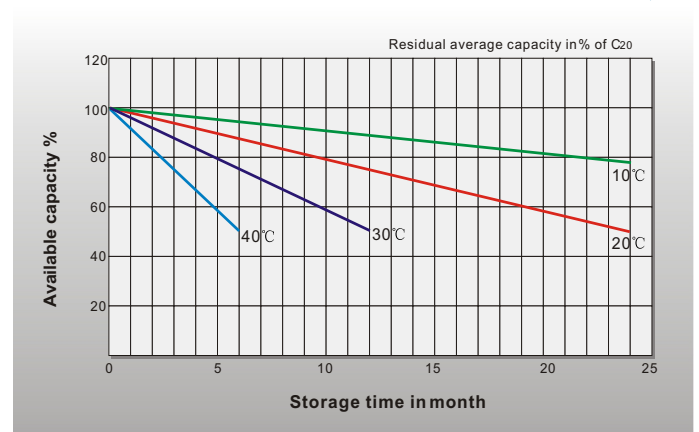

## Sales Office



**ZAFER ENERGY SYSTEMS IND.&FOREIGN TRADE CO.LTD.**

**Head Office**

BEYLİKDUZU O.S.B MERMERCILER SAN SİT. 9. CAD. NO:18

BEYLİKDUZU/İSTANBUL

TEL : +90(212)632 77 75

FAX : +90(212)632 05 87

WEB : <http://www.zaferenergy.com>